

SHIELD Air Mortar

051-831-5400
E-mail: kyss11@ssyenc.co.kr

1. 개요

1-1. 프로젝트 개요

- 시공 : 1997. 11. 20 ~ 2005. 08. 20
- 총 길이 : L=10.394km
- (SHIELD L=3,183m SHIELD L=1,686m NATM L=404m TBM L=4,490m L=631m)

1-2. 터널 직경

SHIELD (직경 : 3m)
(직경 : 1650mm)

300mm), (직경 : 100mm)
Air Mortar

1-3. 공기 분사

가

2. 공기 분사 방법

2-1. 공기 분사 방법

1) 3.0m, L=1,600m SHIELD TUNNEL Air Mortar (V=7,500m³) 가 POINT BLEEDING

2) PLANT

(가)

3) 공기 분사 방법

4) Air Mortar 가 SHIELD TUNNEL

[1] PLANT ()

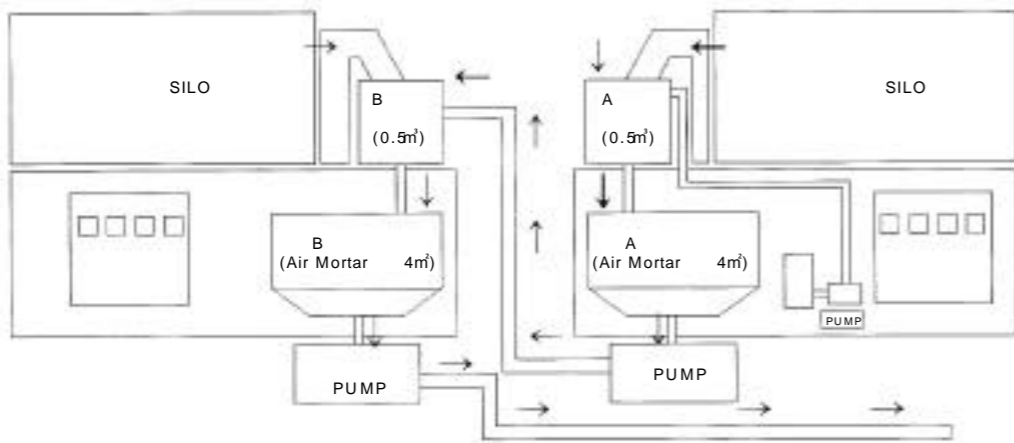

[2] ()

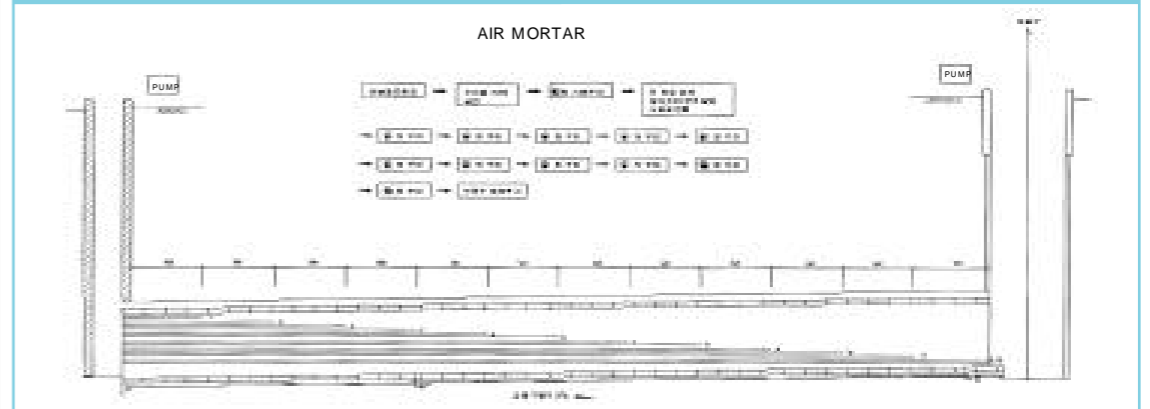

[3] ()



2-2. 공기 분사 방법

1) FLOW

8 ~ 11SEC

2) 가 가 1 PLANT 1

3)

(kg)	(Kg)	(Kg)	(Kg)				
280	180	1.5	864	X	X	X	가
280	90	3.4	872	9.7sec	0%		28=5~7kg

4) Air Mortar 가

W1 W2 + W3 O.K

W1 :

W2 :

W3 :

W1 = Segment + 1650 +
300 + Air Mortar

3. 공기 분사 방법

SHIELD TUNNEL

Air Mortar 가

	가 가 1SPAM
-	(13SPAM)
가 - 1	Bentonite 50% 가 (80mm) 30%
- PLANT 2	1 50%
- 3	45days 1.5
-	Air Mortar 가
- 1	가
-	1

ILM Steel Nose

6
033-645-6877
E-mail: ygkim@ssyenc.co.kr

(I.L.M) 7 P.S.C
Box Girder
ILM 1
(Steel Nose) () ()
가

1-1. 50m, 330m, 2

1-2. 1) 2) 3) 가

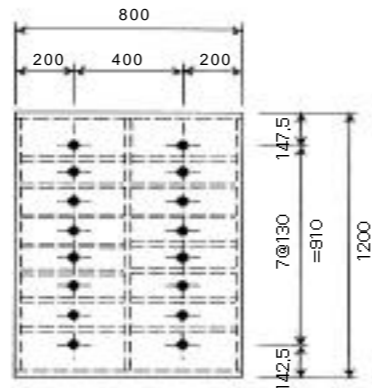
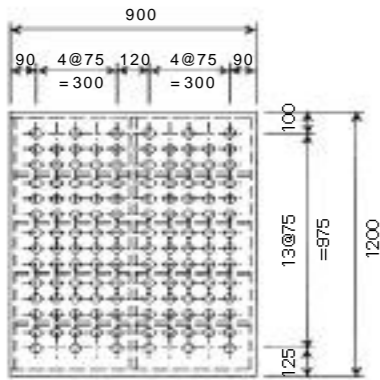

- 1	33가	-	(36mm, 44가)
-	1	-	
- 1	33가	-	(36mm, 44가)
- Steel Nose		-	
- Steel Nose	4	-	Steel
가		-	Nose

3. Steel Nose 1 ~ 2
Plate 가 가 , Anchor 가 ,
가 , 4 가

가			
(1) (1-0.5) L=2.80mX33가 = 940.80m W=940.80mX0.787kg/m = 740kg 672 (25) L=2.20mX33가 = 739.20m L=739.20m (1-0.5) (36mm) 0.740tonX1,200,000 = 888,000 672 X45,000 = 30,240,000 (25) 739.20mX1,500 = 1,108,800 739.20mX1,800 = 1,330,560 (1) 1,000,000 : 34,567,360	(1) (36mm) L=2.80mX44가 = 123.20m W=123.20mX7.127kg/m = 878kg 88 (51) L=2.20mX44가 = 96.80m L=96.80m (36mm) (25) 0.878tonX1,800,000 = 1,580,400 88 X200,000 = 17,600,000 (25) 96.80mX5,500 = 532,400 96.80mX3,500 = 338,800 (1) 1,000,000 : 21,051,600	() 27,031,520	
(1) STEEL NOSE : 5 80ton : 5 () 5 X5 X120,000 = 3,000,000 5 X1,200,000 = 6,000,000 : 9,000,000	(1) STEEL NOSE : 3 80ton : 3 () 3 X5 X120,000 = 1,800,000 3 X1,200,000 = 3,600,000 : 5,400,000	() 7,200,000	
34,231,520			

(1) : 11 : 6 : 3 : 2	(1) : 7 : 5 : 1 : 1	() 8
(1) : 12 : 3 : 7 : 2	(1) : 7 : 2 : 4 : 1	() 10
18		

가

|
|
| 031-276-1841
| E-mail: leehj513@ssyenc.co.kr

1. _____

1-1. 가
PSC-SLAB 3

2. _____

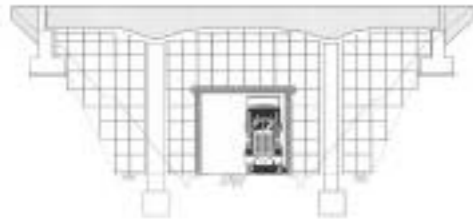

- 가 15m 3
Slab



- 가 가

-
- 가

-
-
-
-

, Slab

가

1-2.

- 1) 가 가
- 2) 가 가
- 3) 가 가

	- : 5 - : 70 - : 25	- : 15 -가 : 55 - : 20
	100	90

3. _____

3
가
가
가

